

PAS 381S (15") Separation System

Low Shock Satellite Separation System for your mission

The RUAG 381S Separation System is the smallest member of our family of Low Shock Separation Systems designed for interfacing small sized spacecraft with Launcher Vehicles. It has been developed to fit the ESPA 15" adapter interface.

The Separation System includes a low shock clamp band separation system, interface rings, umbilical connection and a separation spring set. With our CBOD-LT™ Separation System Release Mechanism we can provide the unique combination of high load capability and a low shock release.

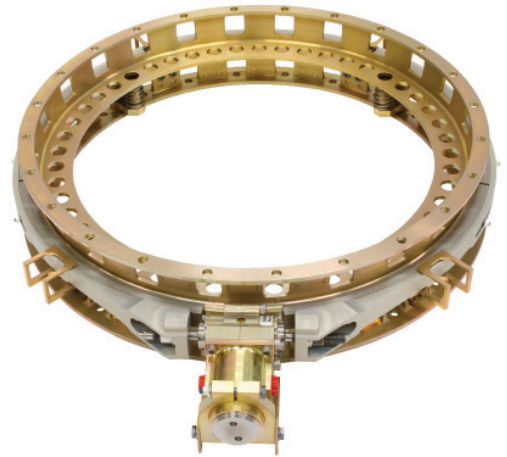

Building on heritage and reliability

The PAS 381S Separation System is based on the already flight proven systems at RUAG. Developed for over 30 years, the RUAG Space product family to date includes a broad range of Separation Systems, spanning diameters from 381 mm to 2624 mm (15" to 103").

Our Separation Systems have an outstanding flight record. To date more than 630 in-orbit separations have been carried out with a success rate of 100%! Our customer base includes launch service providers, satellite builders, government entities and national space agencies. We work closely with the customers during the spacecraft design phase to establish a fully compatible design.

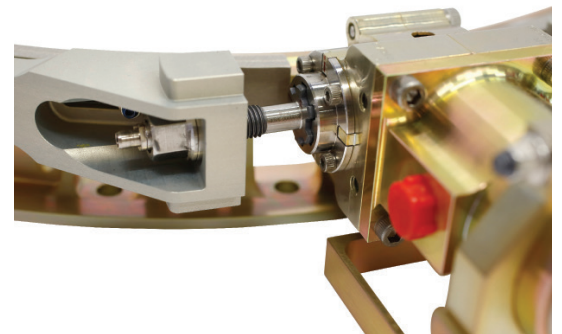
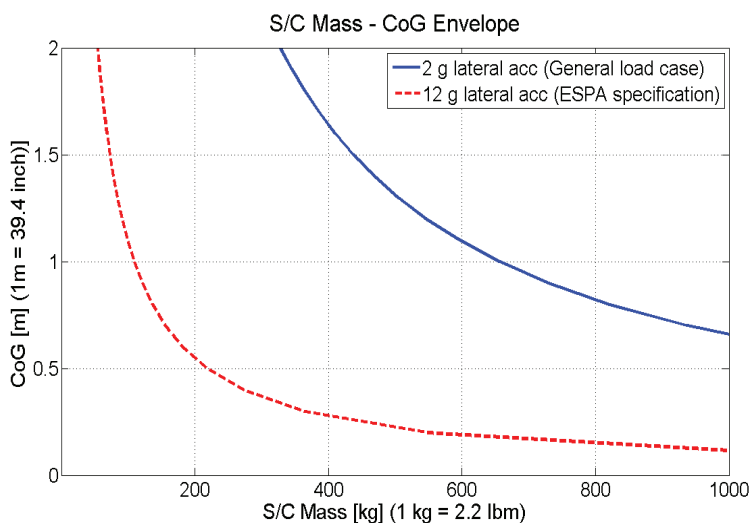

Together
ahead. **RUAG**

Main characteristics of PAS 381S

		Unit	Value ¹⁾
Bolt pretension (nominal)		kN	11
Mass	Total ¹⁾	kg	3.7
	Separated mass	kg	0.98
Dimensions	Height ²⁾	mm	79
I/F	Passive ring		24 x 1/4 inch bolts placed on a diameter of 381 mm (15 inch ESPA I/F)
	Active ring		24 x 1/4 inch bolts placed on a diameter of 381 mm (15 inch ESPA I/F)
	Initiator type		Pacific Scientific 103377-449 Hi-Shear PC23-250 ASI PD22240024-009 USI 1F01084-1
Separation springs	No. of springs	pcs	4 to 24
	Spring energy ³⁾	Joule	1.1
Release type			Low shock < 100 g's @ 1 kHz
Shock output			Low shock < 100 g's @ 1 kHz

¹⁾ Mass of the standard system including passive ring. Can be optimized to meet specific needs.

²⁾ Height includes separation springs, active and passive rings.

³⁾ Energy per spring.

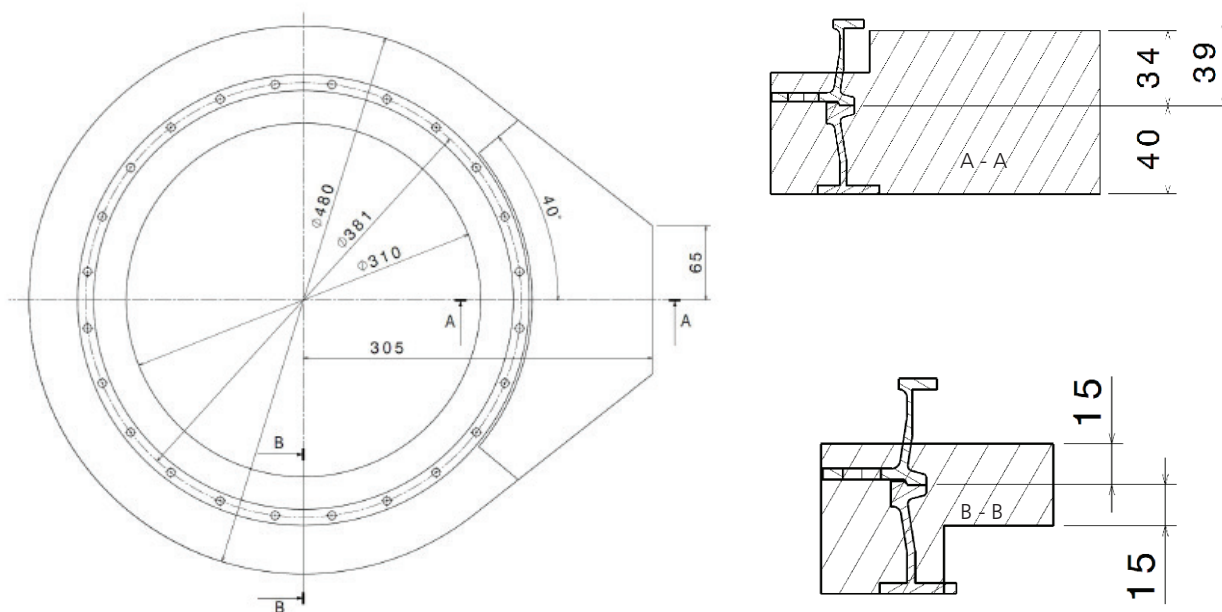

Illustrative Drawing and Nominal Release Envelopes