

Space Equipment Power



PCU 50V

A single integrated & modular unit to power your Satcom between 2kW and 6kW

The Power Conditioning Unit (PCU) is a power management equipment intended for GEO telecommunication applications. It controls the spacecraft power from the solar array in sunlight mode and from 1 or 2 batteries during eclipse.

The PCU generates a fully regulated 50V bus for serving small to medium sized satellites with a power requirement ranging from 2kW to over 6kW, compatible with Electric Propulsion and Time Division Multiple Access (TDMA) payload operation mode. It is based on a modular design and can easily be adapted to different power requirements.

Three Domain Control ensures fully autonomous operation in any operational mode and smooth transition between them. The PCU delivers excellent efficient performance in both transfer and orbit mission configurations.

Highly reliable for mission durations up to 15 years, the PCU has been designed according to ESA ECSS standards. It is a one failure tolerant unit and after a bus under-voltage event, it is able to restart automatically as soon as any power source becomes available.

KEY FEATURES

- Generates a precise and fully regulated 50V bus ($\pm 0.5\%$), with a maximum ripple up to 0.25V peak to peak, during sunlight and eclipse and under all spacecraft operating conditions
- Modular concept providing power outputs ranging from 2kW to 6kW in 1000W steps
- Implements a centralised low impedance point for power distribution (Platform and Payload)
- Fully autonomous operation without support from any other satellite subsystems under all mission operational conditions including contingency situations
- Single Point Failure Free architecture
- Battery connection / disconnection through Solid State Switches in the Battery Discharge Regulator (BDR)
- Autonomous battery disconnection in the event of an over discharge
- Capability to operate with either one or two independent batteries. In the case of two batteries, specific control electronics guarantee balanced battery discharge even after one failure
- Power Modules include 3 Sequential Switching Shunt Regulators (S3R) sections plus 1 BDR to optimise thermal dissipation and control
- Li-Ion battery charge / discharge control via a fully autonomous hardware control loop
- Communication with the OBC via MIL STD 1553 Bus
- Compatible with Multi Junction High Capacitance Ga-As Solar Cells

CUSTOMERS / APPLICATION

- Telecommunications, SGEO Platform

INTERFACES

- Power bus: 50V $\pm 0.5\%$
- Battery: Li-Ion
- Dialog: MIL STD 1553

ENVIRONMENTS

- Thermal: -15°C to $+60^{\circ}\text{C}$ (operating), -25°C to $+60^{\circ}\text{C}$ (non operating), -25°C (start-up)
- Radiation: total dose (15 years GEO orbit), SEU, latchup immune
- Lifetime: 15 years

MAIN APPLICATION FIELDS

- All GEO applications

DEVELOPMENT STATUS

- 5kW version qualified in March 2012
- First FM delivery by end 2012

BUDGETS

- Mass: 25kg @ 5.5kW
- Volume: 480 to 505 x 260 x 265mm³
- Power: 2kW to 6kW @ 50V Fully Regulated
 - > 96% BDR efficiency @ 5kW, 36V battery voltage
 - > 97% BCR efficiency @ 14A battery charge, 36V battery voltage
 - > 98.9% S3R efficiency

PCU architecture

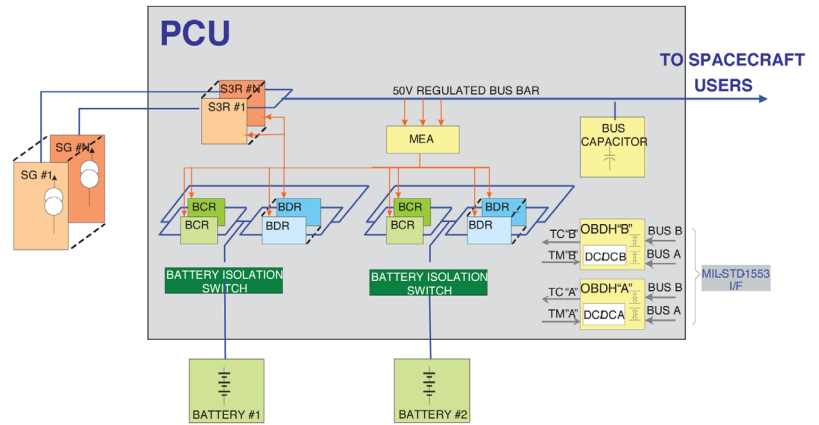

The PCU in its environment: solar array, battery, Spacecraft bus bar and OBC

- The Solar Generator Electrical Power is conditioned via Sequential Switching Shunt Regulation (S3R). It is either dumped to the bus or shunted to satisfy the bus load demand during sunlight periods.
- The battery is charged during sunlight through a dedicated converter (BCR) autonomously controlled to prevent battery thermal stress. During eclipse periods or Solar Generator power defects, the energy stored in the battery fulfils the bus power demand via the Battery Discharge Regulators (BDR).
- The PCU can operate with either one or two independent batteries. In case of a dual battery configuration, independent battery management is performed through dedicated BCRs and BDRs per battery. In this case, the failure tolerant Battery Discharge Balance (BDB) electronics guarantees that the current extracted from both batteries is the same.

Main performances of the PCU

Solar array Power Control S3R

- Switching Shunt Regulator: Up to 24 sections, 7A per section
- 20A maximum Solar Array peak current even after one failure
- No power loss after a failure
- Compatible with Multi Junction Solar Array cells up to 1.5 μ F per 7A section (7 μ F/A per 3J Ga-As cell)

Battery Discharge Regulator, BDR Weinberg topology

- Up to 1000W per module
- Independent solid state battery isolation device per BDR module
- 27.5V to 48V battery voltage I/P range
- 3% BDR output current matching

Battery Charge Regulator, BCR

- Low ripple buck topology
- 14A maximum output current
- Independent solid state battery isolation device per BCR module
- 27V to 48V battery voltage O/P range
- Charge Method: Taper Charge (Constant Current/Constant Voltage)

Main Error Amplifier, MEA

- Bus regulation better than 0.5%
- Bus ripple better than 0.5% peak-peak, compatible with last generation telecom loads
- Compatible with TDMA load mode
- Compatible with 6.6kW peak consumption @ electric propulsion operation